

Gilbarco®

Pumps & Dispensers Series SK700-2™

Site Preparation

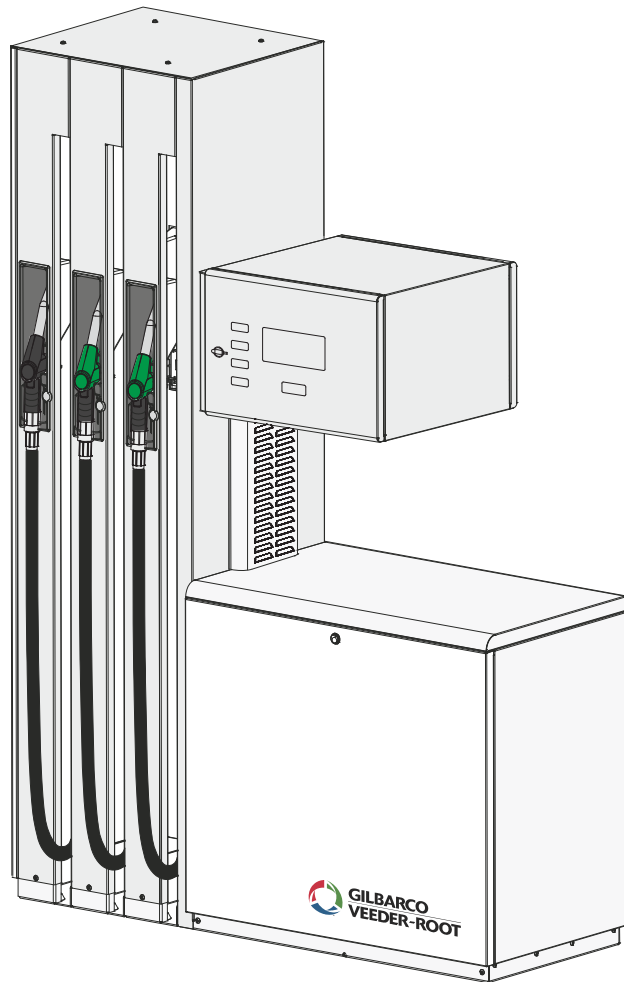

Document not subject to updating service

Table of Contents

1	Read Me First	3
2	General Description.....	3
2.1	<i>Dispenser Orientation.....</i>	4
2.2	<i>Grade Locations</i>	4
3	Datasheet for one product.....	5
4	Datasheet for two products	6
5	Datasheet for three products	7
6	Datasheet for four products	8
7	Datasheet for five products	9
8	Datasheet for five products in one hydraulics frame.....	10
9	Datasheet for three products + UHF	11
10	Datasheet for four products + UHF	12
11	Datasheet for one product UHF.....	13
12	Subframe with brackets for riser pipe, 1-4 products.....	14
13	Subframe with brackets for riser pipe, 5 products and versions with UHF	15
14	Subframe with brackets for riser pipe, 5 products in one hydraulics frame.....	16
15	Junction Box Wiring.....	17
16	Proposal for suction dispenser & vapour connections.....	18
16.1	<i>Subframes</i>	18
16.2	<i>Drip Guards.....</i>	18
16.3	<i>Vapour Recovery Pipes.....</i>	18
16.4	<i>Proposal for suction dispenser fuel connections – plastic pipework</i>	19
16.5	<i>Dimensions for STP connections</i>	19
16.6	<i>Proposal for shear valve connection with STP</i>	20
16.7	<i>Operation conditions STP.....</i>	20

1 Read Me First

If equipment is to be used to dispense Petrol, then the words 'PETROL' (or PETROLEUM SPIRIT), LPG, HIGHLY FLAMMABLE, NO SMOKING and SWITCH OFF ENGINE should be positioned so that the warnings and instructions are brought to the attention of customers immediately on their arrival at the dispensing equipment.

At attended self-service and attendant operated filling stations, the following devices should be installed :

1. At a location readily accessible for quick operation by an attendant at the control point - an Emergency Stop push button switch (or switches) for switching off all fuel dispensers and other electrical equipment within the hazardous zone, with a prominent adjacent notice :(e.g. PETROL PUMPS - EMERGENCY STOP)

2. On the forecourt readily accessible to firefighters but out of reach of the general public - an Emergency Switch which will isolate all fuel dispensers and other electrical equipment within the hazardous zone, with a prominent adjacent notice: (e.g. PETROL PUMPS - SWITCH OFF HERE).

Note: These switches should NOT turn off the forecourt lighting.

It is also recommended that for self-service filling stations a public address system for communicating with customers is installed. Please refer to any national or local regulations for more details on the specific requirements with respect to petrol dispensing.

At unattended filling stations special safety provisions will be necessary. Please refer to any relevant national or local regulations that may be in force.

Any dispensing areas of the forecourt should be adequately lit for safety purposes at all times of use. The illuminance at ground level and the read-out level of displays should not be less than 100 lux.

Any 'Third Party' self-service equipment used with this dispenser should comply with the requirements of the EC Machinery Directive in respect of user friendly software between the operator and the control system.

DANGER FROM MOVING PARTS : The electrical power to this equipment must be removed prior to any installation or maintenance work being carried out.

WARNING: THE UNIT BEING THE SUBJECT-MATTER OF THIS MANUAL SHALL BE INSTALLED AND COMMISSIONED BY TRAINED PERSONNEL.

Trained personnel means people with the appropriate technical education and experience required to:

- carry out operations in areas accessible by technical assistance staff,
- be aware of the dangers involved in carrying out the operations, and be instructed about the measures required to minimise those dangers

After any installation, maintenance work or switch-off by the air separator in the pumping unit, check for leaks on the hydraulic circuits!

When cleaning the GRP panels on your pump, always use a soft damp cloth, NEVER clean with dry cloth.

Only genuine Gilbarco parts should be used on this equipment.

All equipment connected to the Control, Data or Point of Sale terminals of this Dispenser must comply with SELV (Safety Extra Low Voltage) requirements as defined in Standard EN60950.

The dispenser is in accordance with the directive measuring instruments 2004/22/EG. The approval number is T10055.

2 General Description

The SK700 is a grouped hose dispenser. It is capable of dispensing Petrol, Diesel, Ethanol 85 or LPG and can be supplied as a self-contained pumping unit or as part of a Pressure fed dispenser (STP) installation. Both sides of the dispenser can dispense fuel simultaneously, acting as two independent fuelling positions.

The SK700 can operate in 'Stand-Alone' mode or they can be used as part of a complete Self-Service forecourt installation. They can communicate with any other approved Self-Service control console via Gilbarco 2Wire, IFSF - Lon protocol, ER3, ATCL, or PUMA LAN.

Dispensers may be fitted with up to 12 hoses and are supplied as complete assemblies ready to be secured to the island and connected to the fuel supply pipes and the mains electrical supply cable. All internal connections, i.e. wiring, hydraulics and vapour recovery piping, are already assembled, in position and ready for installation.

High-Flow versions are available which can deliver up to 120 litres per minute. Two speed versions are also available.

A wide range of optional features are available, including Vapour Recovery.

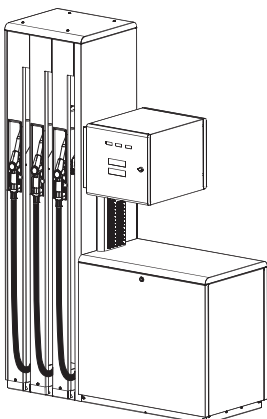

2.1 Dispenser Orientation

The diagram shows the grade layout inside the dispenser and also shows how to identify which side of the dispenser you are working from. Simply put, if the column is to the left of the main transaction display then you are on the left hand side (LHS) or 'Side 1' of the dispenser. If the column is on the right of the main transaction display you are on the right hand side (RHS) or 'Side 2'.

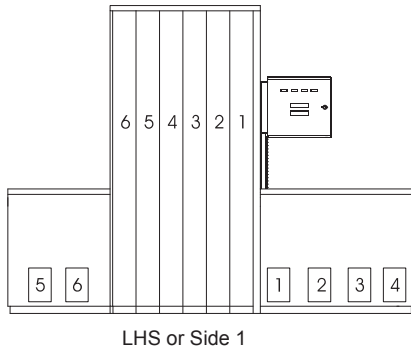

2.2 Grade Locations

The numbers on the hose cabinets and on the monoblocks represent how grades are mapped and referred to in the programming sequences.

3 Datasheet for one product

1 Product, 40 l/min, Suction or STP, with Vapour Recovery and Preset

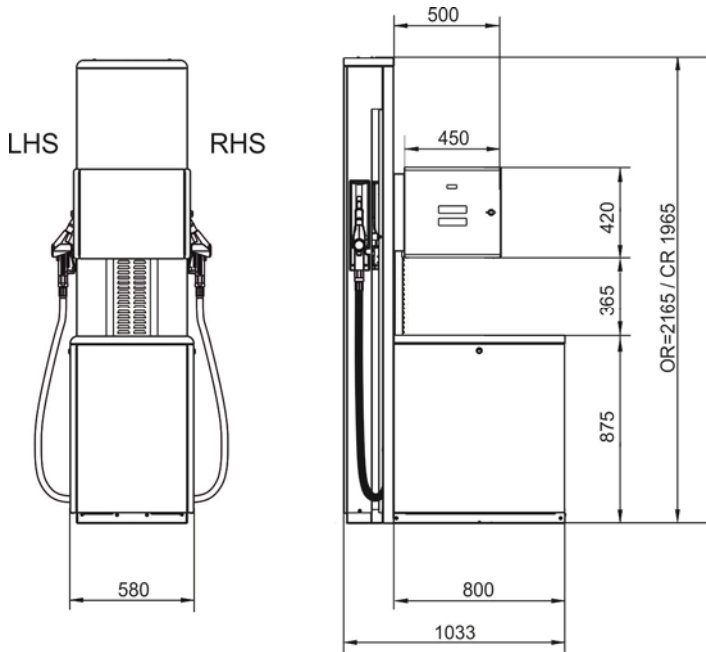

All Dimensions in Millimetres

Option: Suction connection kit
140 826 683 For GPU-90 & GPU-140

Footprint Details Right Side of Dispenser (RHS)

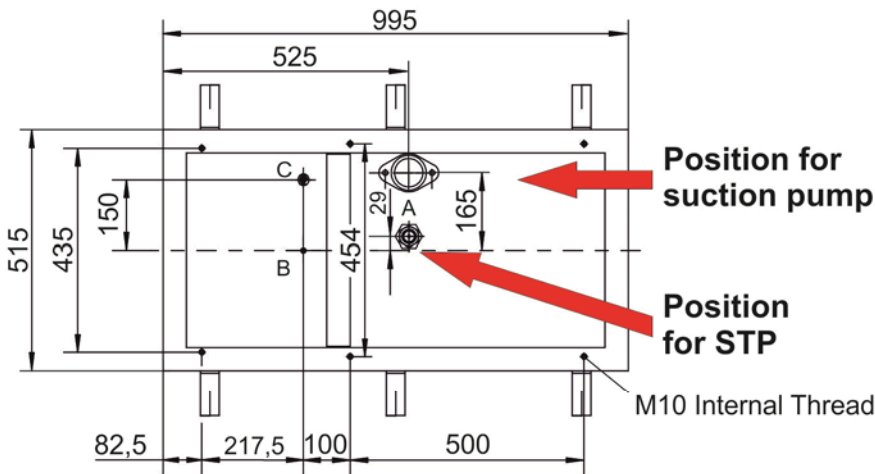

Key to Symbols
A - Grade 1
B - Cable Riser
C - Vapour Recovery

Subframe
Part No. - 140 868 951

Left Side of Dispenser (LHS) It is recommended that Vapour Recovery return pipes are installed where this is may be a future requirement.

Module Configuration and Maximum Current

Suction Pump	Submerge Turbine Pump (STP)
Motor supply, maximum current	Vapour Recovery, maximum current
1 Phase Versions, 230V = 7,0 Amps	3 Phase Motors = 1,0 Amps
3 Phase Versions, 230V = 5,0 Amps	1 Phase Motors = 3,0 Amps
3 Phase Versions, 400V = 3,5 Amps	Electronic supply, maximum current
Electronic supply, maximum current	All Versions = 6,0 Amps
All Versions = 6,0 Amps	

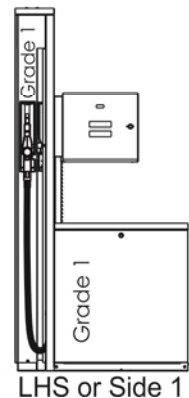
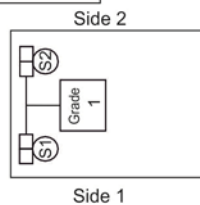

4 Datasheet for two products

2 Products, 40 l/min, Suction or STP, with Vapour Recovery and Preset

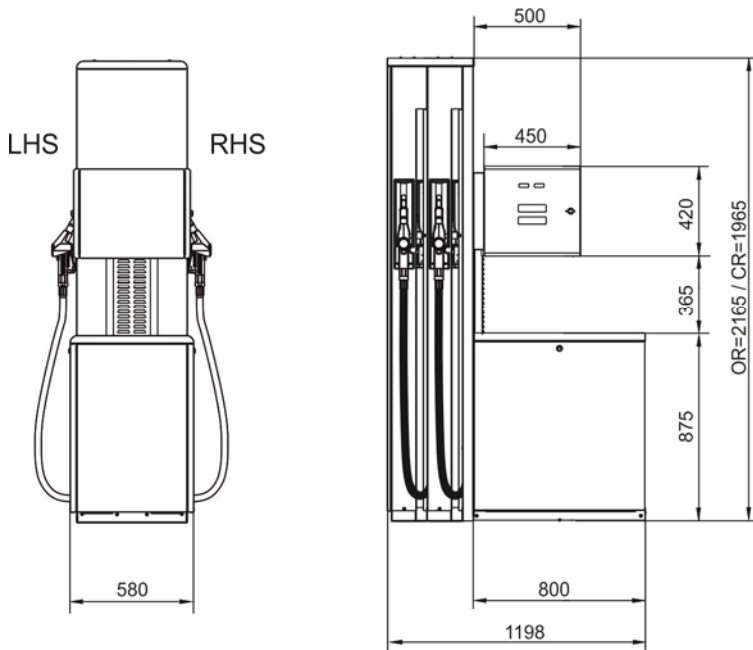

All Dimensions in Millimetres

Option: Suction connection kit
140 826 683 For GPU-90 & GPU-140

Footprint Details

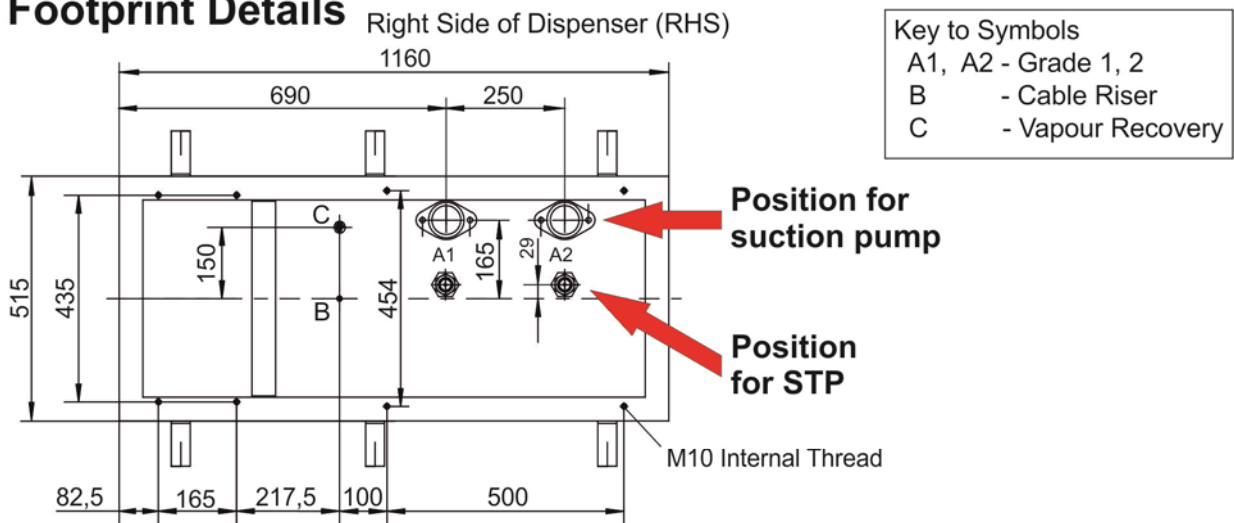

Subframe
Part No. - 140 868 481

Left Side of Dispenser (LHS)

It is recommended that Vapour Recovery return pipes are installed where this may be a future requirement.

Module Configuration and Maximum Current

Suction Pump	Submerge Turbine Pump (STP)
Motor supply, maximum current	Vapour Recovery, maximum current
1 Phase Versions, 230V = 12,5 Amps	3 Phase Motors = 1,0 Amps
3 Phase Versions, 230V = 10,5 Amps	1 Phase Motors = 3,0 Amps
3 Phase Versions, 400V = 6,0 Amps	Electronic supply, maximum current
Electronic supply, maximum current	All Versions = 6,0 Amps
All Versions = 6,0 Amps	

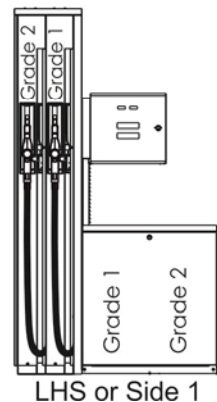
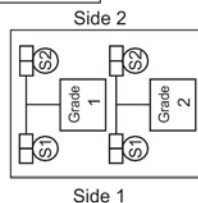

5 Datasheet for three products

3 Products, 40 l/min, Suction or STP, with Vapour Recovery and Preset

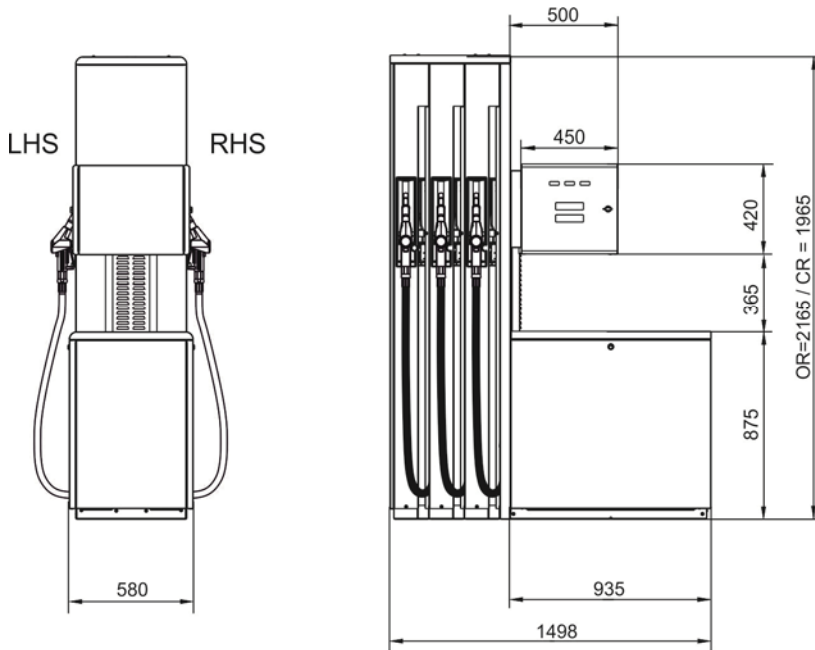

All Dimensions are in Millimetres

Option: Suction connection kit
140 826 683 For GPU-90 & GPU-140

Footprint Details

Right Side of Dispenser (RHS)

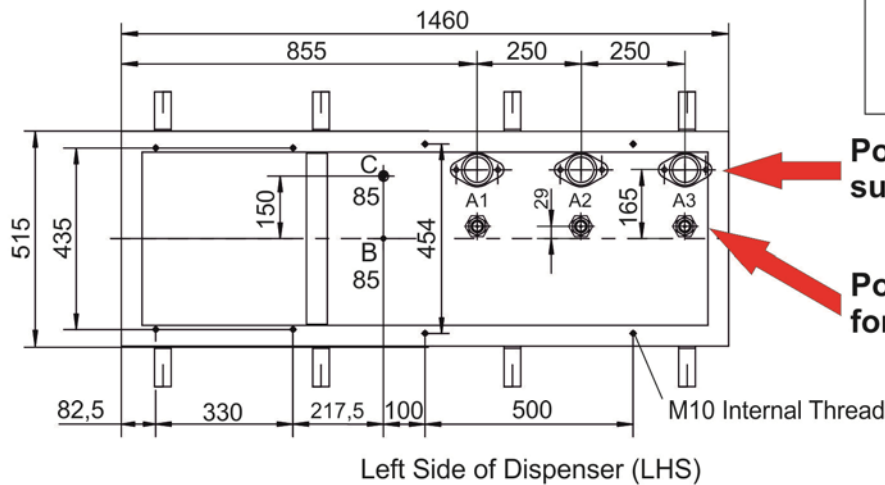

Key to Symbols
A1- A3 - Grade 1, 2, 3
B - Cable Riser
C - Vapour Recovery

Position for suction pump

Position for STP

Left Side of Dispenser (LHS)

Subframe
Part No. - 140 865 831

It is recommended that Vapour Recovery return pipes are installed where this may be a future requirement.

Module Configuration and Maximum Current

Suction Pump	Submerge Turbine Pump (STP)
Motor supply, maximum current	Vapour Recovery, maximum current
1 Phase Versions, 230V = 12,5 Amps	3 Phase Motors = 1,0 Amps
3 Phase Versions, 230V = 10,5 Amps	1 Phase Motors = 3,0 Amps
3 Phase Versions, 400V = 6,0 Amps	Electronic supply, maximum current
Electronic supply, maximum current	All Versions = 6,0 Amps
All Versions = 6,0 Amps	

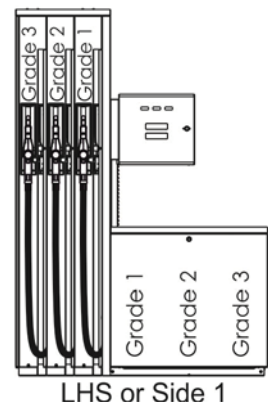
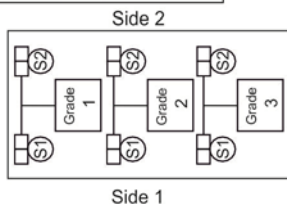

6 Datasheet for four products

4 Products, 40 l/min, Suction or STP, with Vapour Recovery and Preset

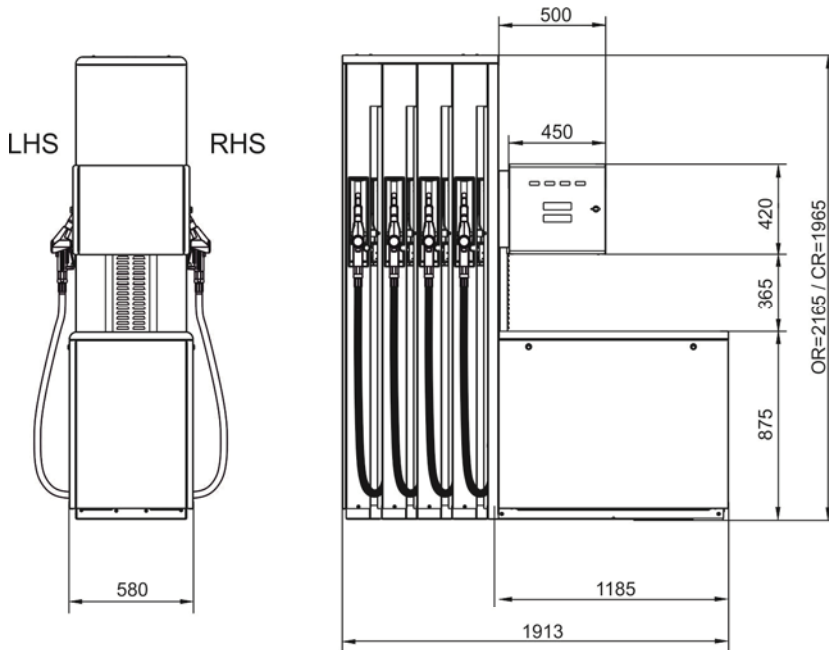

All Dimensions are in Millimetres

Option: Suction connection kit
140 826 683 For GPU-90 & GPU-140

Footprint Details

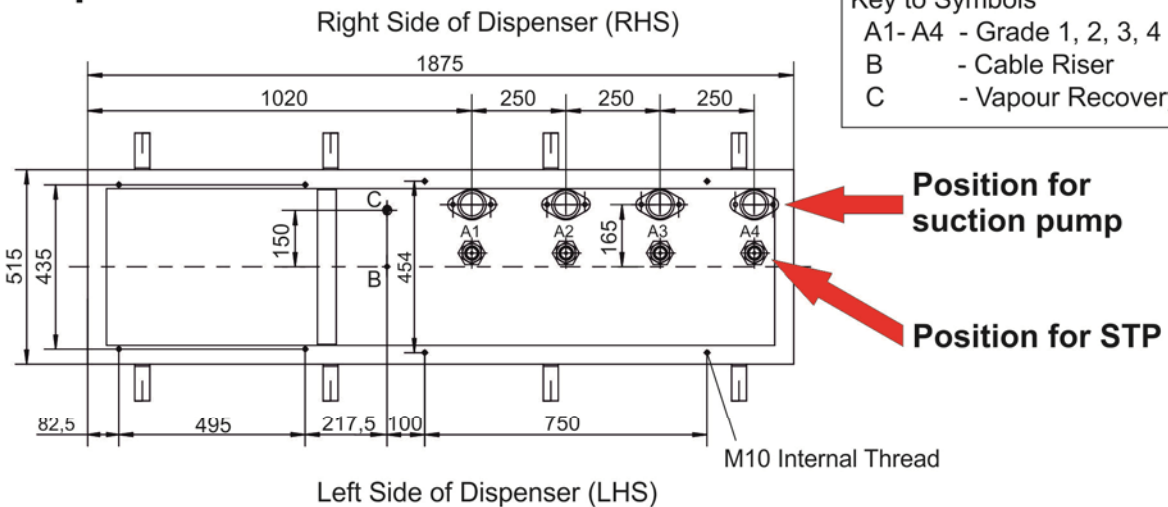

Subframe
Part No. - 140 868 681

It is recommended that Vapour Recovery return pipes are installed where this may be a future requirement.

Module Configuration and Maximum Current

Suction Pump	Submerge Turbine Pump (STP)
Motor supply, maximum current	Vapour Recovery, maximum current
1 Phase Versions, 230V = 12,5 Amps	3 Phase Motors = 1,0 Amps
3 Phase Versions, 230V = 10,5 Amps	1 Phase Motors = 3,0 Amps
3 Phase Versions, 400V = 6,0 Amps	Electronic supply, maximum current
Electronic supply, maximum current	All Versions = 6,0 Amps
All Versions = 6,0 Amps	

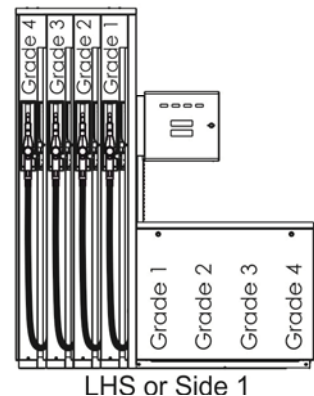
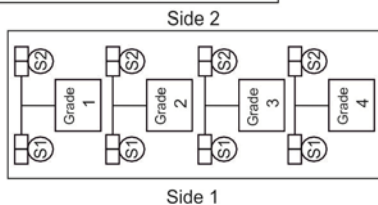

7 Datasheet for five products

5 Products, 40 l/min, Suction or STP, with Vapour Recovery and Preset

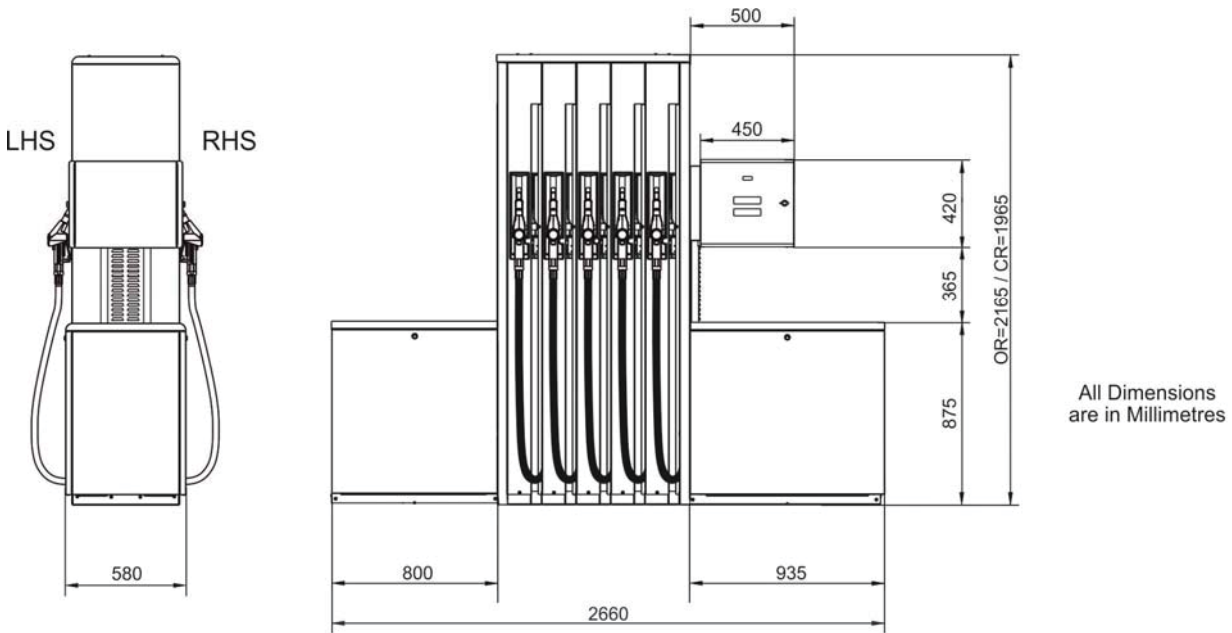

Option: Suction connection kit
140 826 683 For GPU-90 & GPU-140

Footprint Details

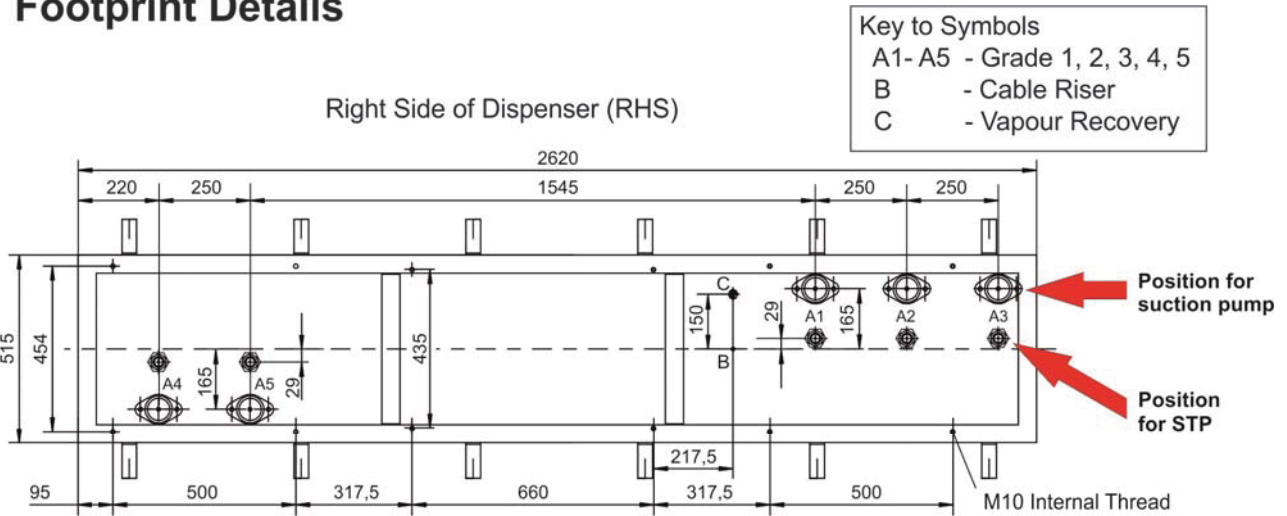

Subframe
Part No. - 140 875 131

Left Side of Dispenser (LHS)

It is recommended that Vapour Recovery return pipes are installed where this may be a future requirement.

Module Configuration and Maximum Current

Suction Pump
 Motor supply, maximum current
 1 Phase Versions, 230V = 12,5 Amps
 3 Phase Versions, 230V = 10,5 Amps
 3 Phase Versions, 400V = 6,0 Amps
 Electronic supply, maximum current
 All Versions = 6,0 Amps

Submerge Turbine Pump (STP)
 Vapour Recovery, maximum current
 3 Phase Motors = 1,0 Amps
 1 Phase Motors = 3,0 Amps
 Electronic supply, maximum current
 All Versions = 6,0 Amps

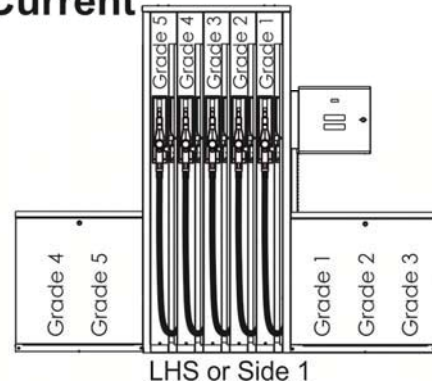
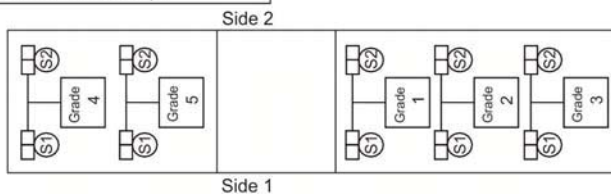

8 Datasheet for five products in one hydraulics frame

5 Products, 40 l/min, Suction or STP, with Vapour Recovery and Preset

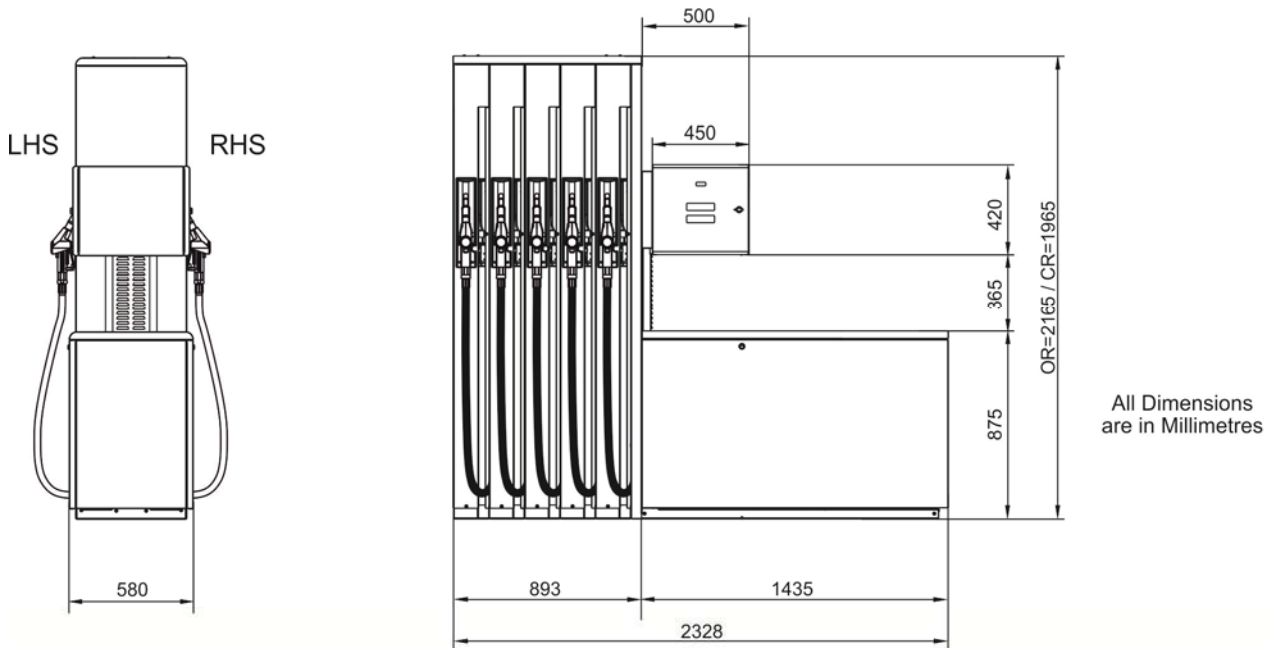

Option: Suction connection kit
140 826 683 For GPU-90 & GPU-140

Footprint Details

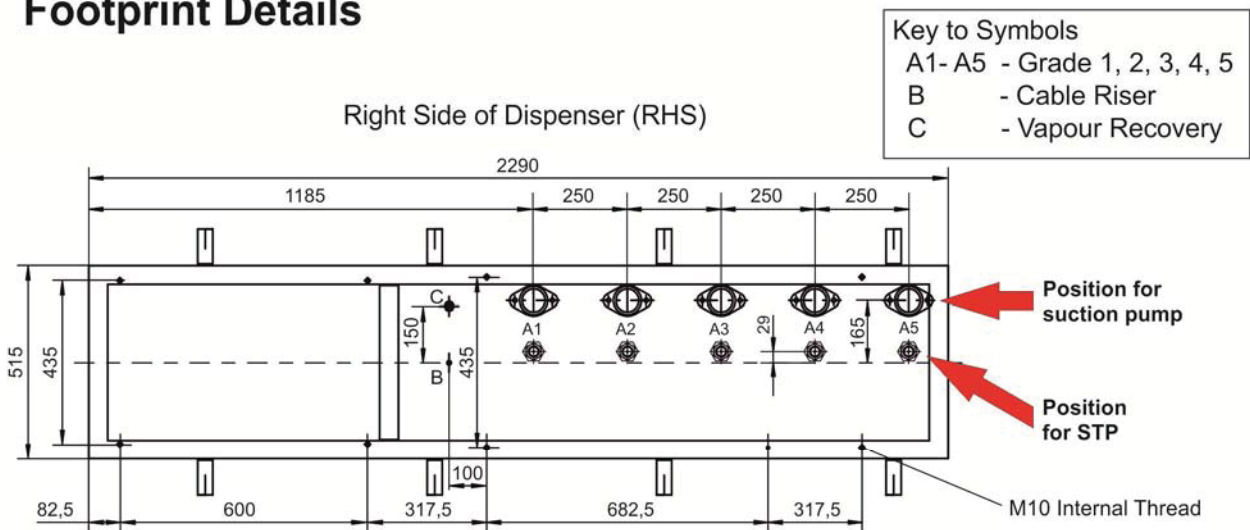

Subframe
Part No. - 140 953 191

Left Side of Dispenser (LHS)

It is recommended that Vapour Recovery return pipes are installed where this may be a future requirement.

Module Configuration and Maximum Current

Suction Pump
Motor supply, maximum current
1 Phase Versions, 230V = 12,5 Amps
3 Phase Versions, 230V = 10,5 Amps
3 Phase Versions, 400V = 6,0 Amps
Electronic supply, maximum current
All Versions = 6,0 Amps

Submerge Turbine Pump (STP)
Vapour Recovery, maximum current
3 Phase Motors = 1,0 Amps
1 Phase Motors = 3,0 Amps
Electronic supply, maximum current
All Versions = 6,0 Amps

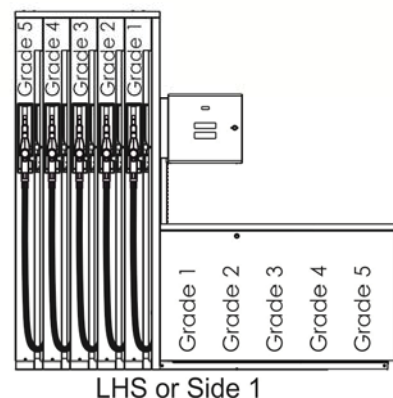
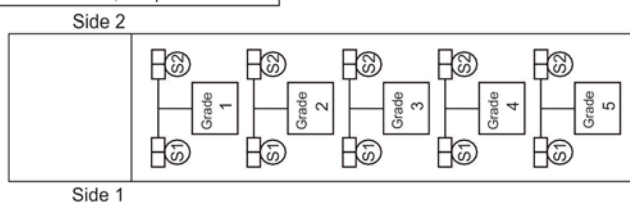

9 Datasheet for three products + UHF

3 Products, 40 l/min + UHF, Suction or STP, with Vapour Recovery and Preset

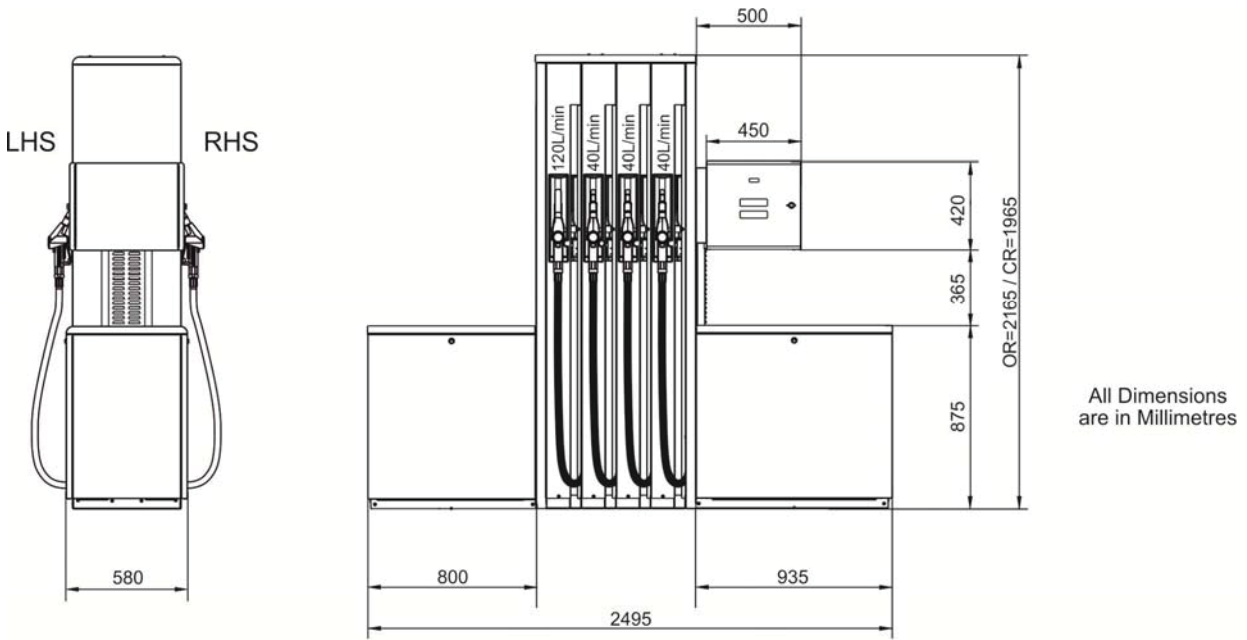

Option: Suction connection kit
140 826 683 For GPU-90 & GPU-140

Footprint Details

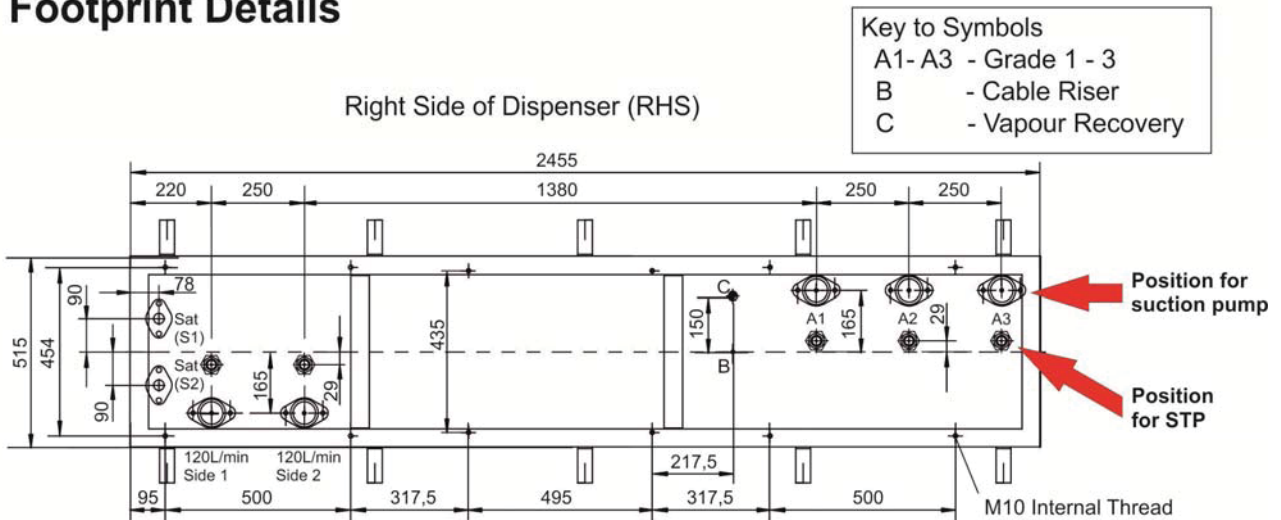

Subframe
Part No. - 140 893 211

Left Side of Dispenser (LHS)

It is recommended that Vapour Recovery return pipes are installed where this may be a future requirement.

Module Configuration and Maximum Current

Suction Pump
Motor supply, maximum current
1 Phase Versions, 230V = Not Used
3 Phase Versions, 230V = 14,0 Amps
3 Phase Versions, 400V = 8,0 Amps
Electronic supply, maximum current
All Versions = 6,0 Amps

Submerge Turbine Pump (STP)
Vapour Recovery, maximum current
3 Phase Motors = 1,0 Amps
1 Phase Motors = 3,0 Amps
Electronic supply, maximum current
All Versions = 6,0 Amps

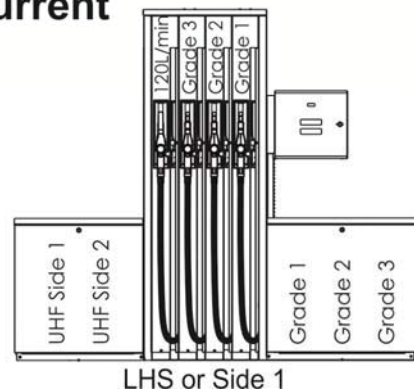
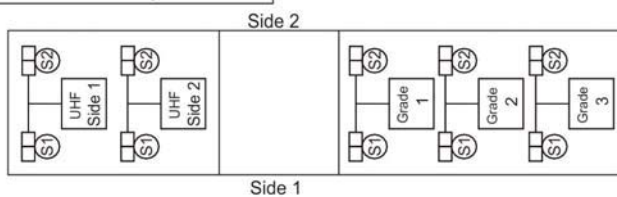

10 Datasheet for four products + UHF

4 Products, 40 l/min + UHF, Suction or STP, with Vapour Recovery and Preset

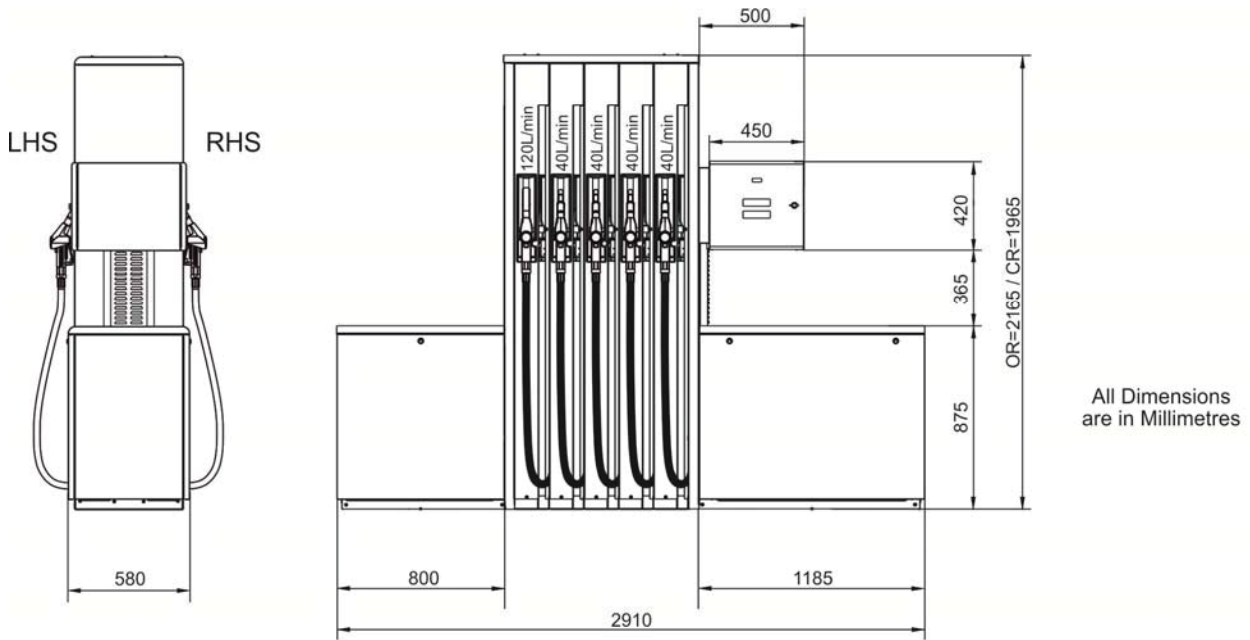

Option: Suction connection kit
140 826 683 For GPU-90 & GPU-140

Footprint Details

Right Side of Dispenser (RHS)

Key to Symbols	
A1- A4	- Grade 1 - 4
B	- Cable Riser
C	- Vapour Recovery

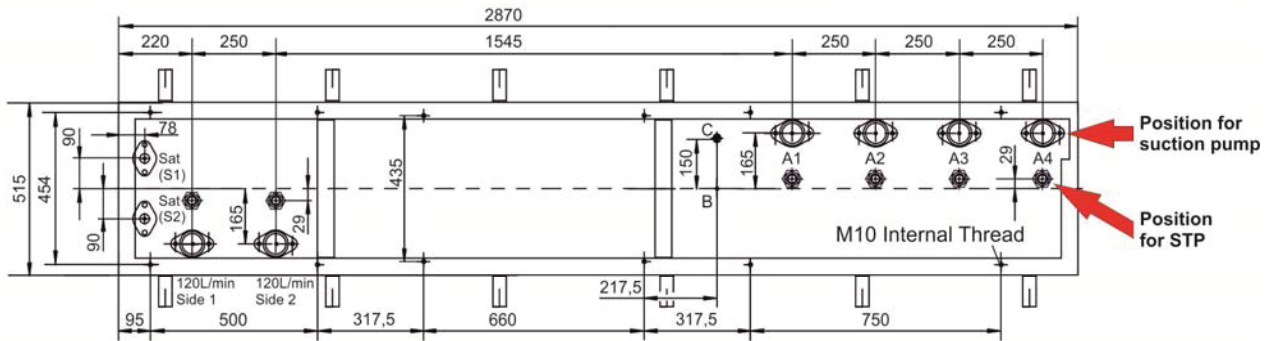

Subframe
Part No. - 140 893 231

Left Side of Dispenser (LHS)

It is recommended that Vapour Recovery return pipes are installed where this may be a future requirement.

Module Configuration and Maximum Current

Suction Pump
Motor supply, maximum current
1 Phase Versions, 230V = Not Used
3 Phase Versions, 230V = 14,0 Amps
3 Phase Versions, 400V = 8,0 Amps
Electronic supply, maximum current
All Versions = 6,0 Amps

Submerge Turbine Pump (STP)
Vapour Recovery, maximum current
3 Phase Motors = 1,0 Amps
1 Phase Motors = 3,0 Amps
Electronic supply, maximum current
All Versions = 6,0 Amps

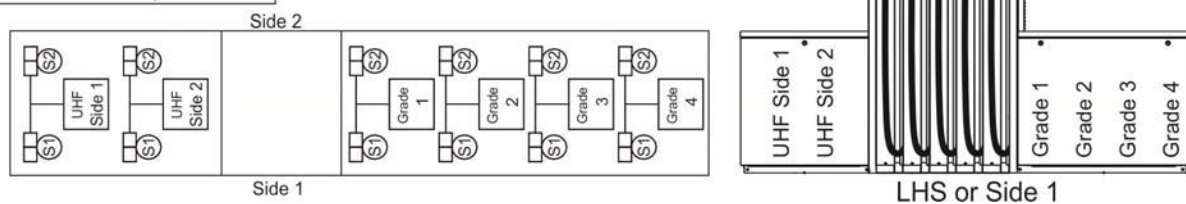

11 Datasheet for one product UHF

1 Product UHF, Suction or STP

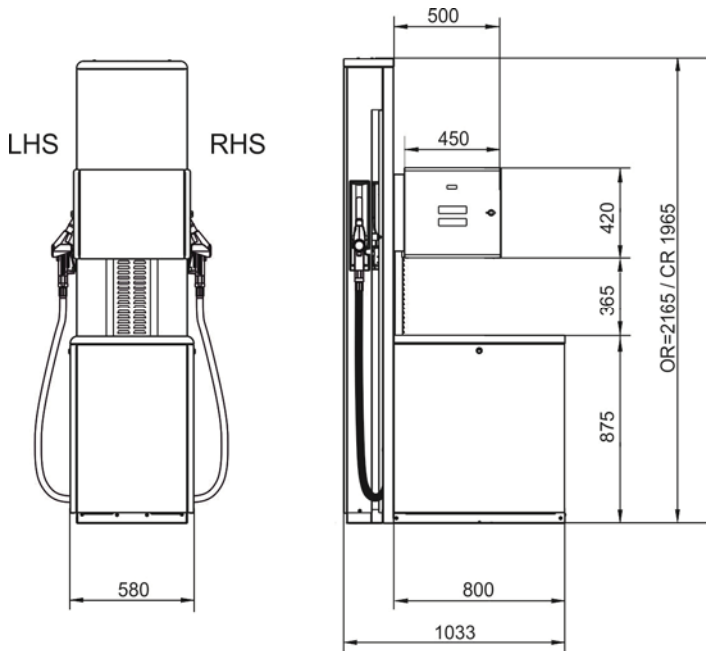

All Dimensions are in Millimetres

Option: Suction connection kit
140 826 683 For GPU-90 & GPU 140

Footprint Details

Right Side of Dispenser (RHS)

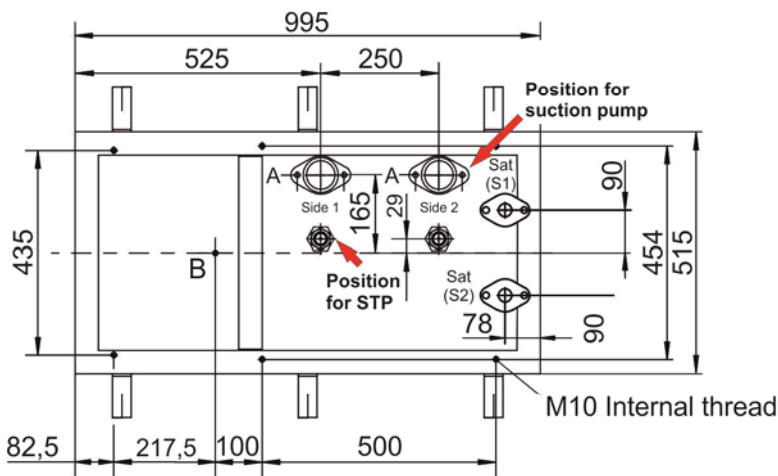

Key to Symbols
A - Grade 1
B - Cable Riser

Left Side of Dispenser (LHS)

Subframe
Part No. - 140 868 951

It is recommended that Vapour Recovery return pipes are installed where this may be a future requirement.

Module Configuration and Maximum Current

Suction Pump	Submerge Turbine Pump (STP)
Motor supply, maximum current	Vapour Recovery, maximum current
1 Phase Versions, 230V = Not Used	3 Phase Motors = 1,0 Amps
3 Phase Versions, 230V = 14,0 Amps	1 Phase Motors = 3,0 Amps
3 Phase Versions, 400V = 8,0 Amps	Electronic supply, maximum current
Electronic supply, maximum current	All Versions = 6,0 Amps
All Versions = 6,0 Amps	

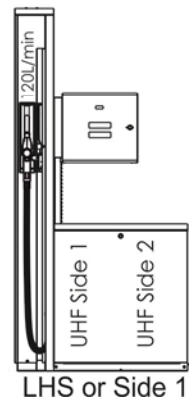
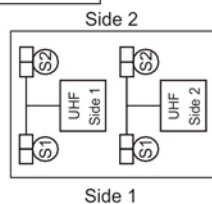

12 Subframe with brackets for riser pipe, 1-4 products

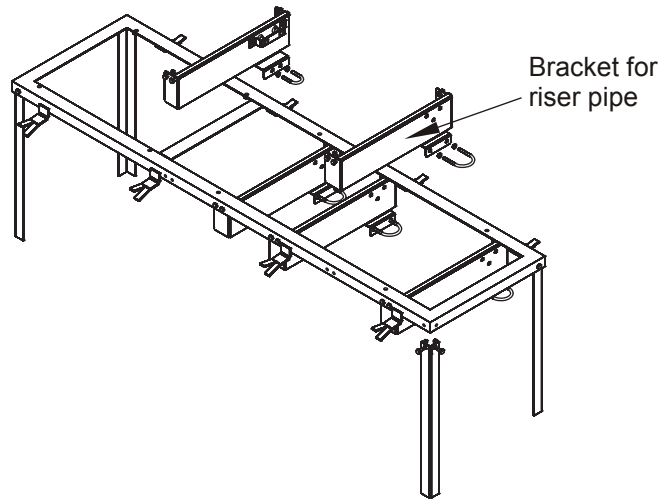

4 Products

Subframe 8/4/8
cpl. with brackets
Part.-No. - 140 868 692

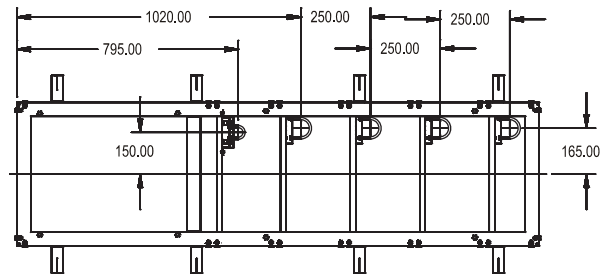
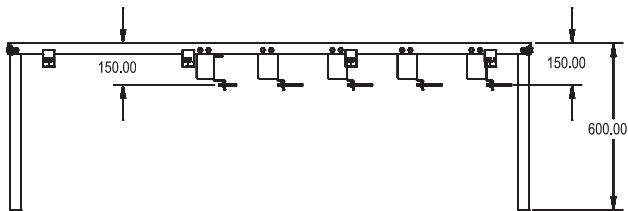

3 Products

Subframe 6/3/6
cpl. with brackets
Part.-No. - 140 865 842

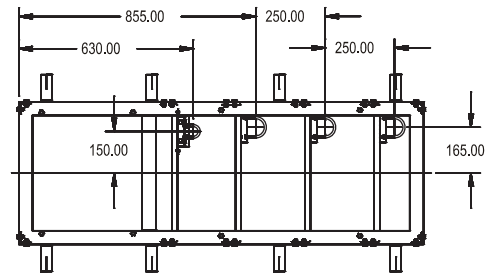
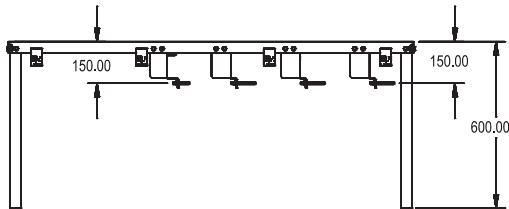

2 Products

Subframe 4/2/4
cpl. with brackets
Part.-No. - 140 868 492

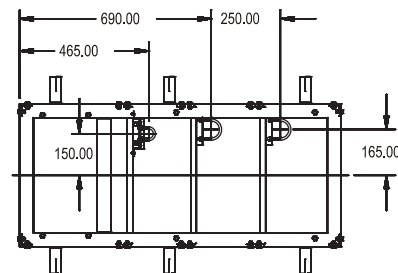
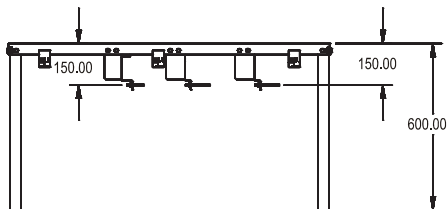

1 Product

Subframe 2/1/2
cpl. with brackets
Part.-No. - 140 868 962

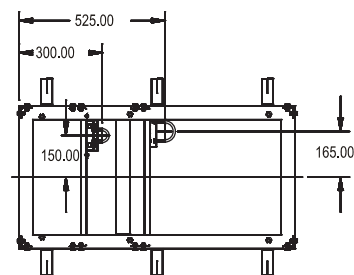
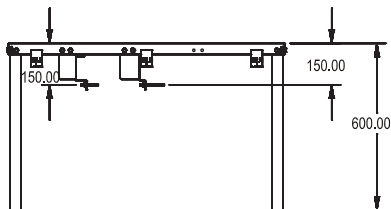

13 Subframe with brackets for riser pipe, 5 products and versions with UHF

5 Products

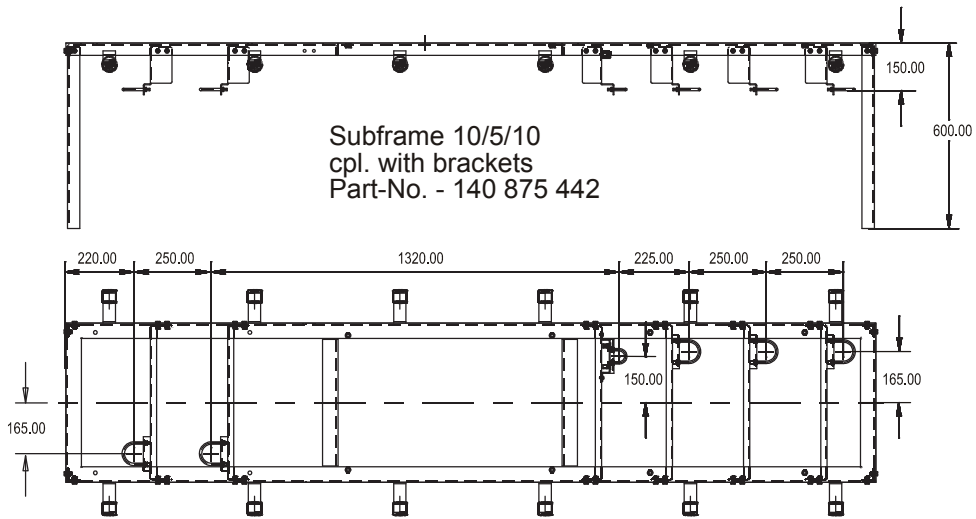

3 Products + UHF

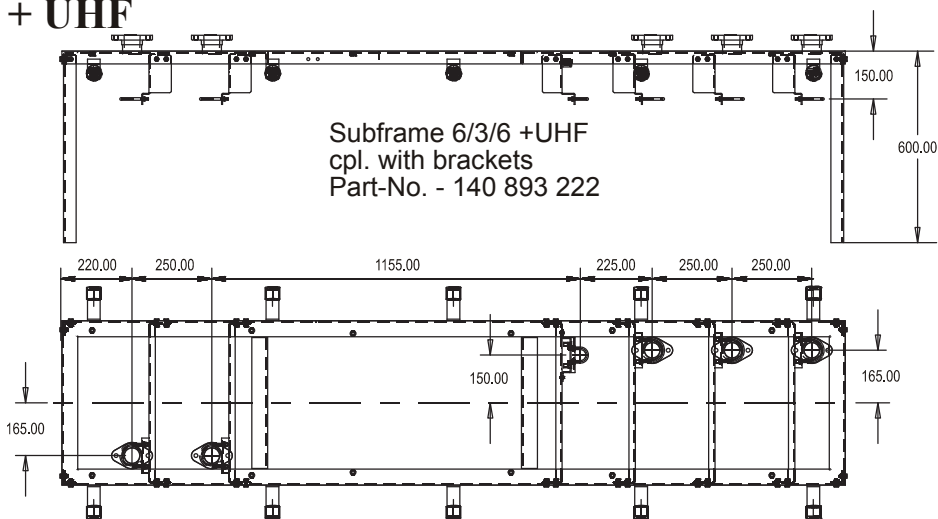

4 Products + UHF

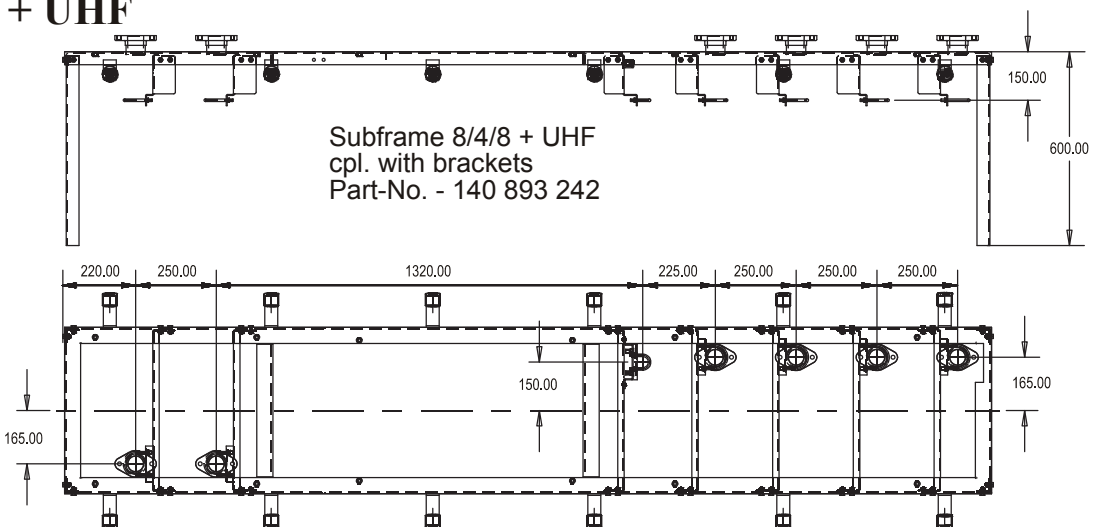

14 Subframe with brackets for riser pipe, 5 products in one hydraulics frame

5 Products in one hydraulics frame

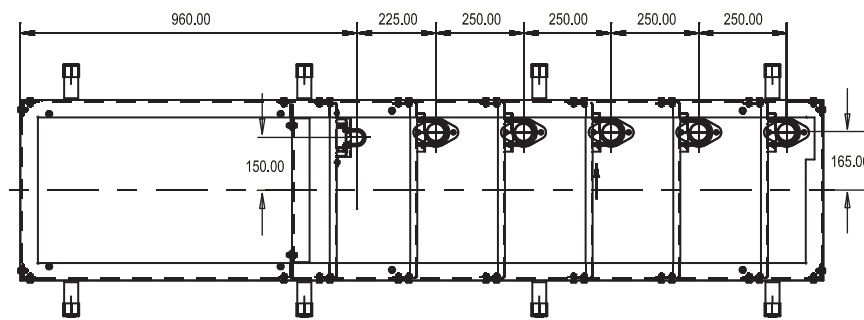
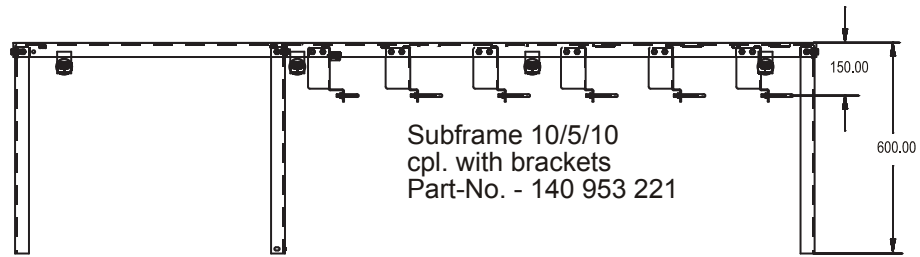

15 Junction Box Wiring

Three Phase Supply

400V ± 10% , 50Hz ± 2Hz
230V +10% -15%, 50Hz ± 2Hz

Power supply

- PE - Main Earth
- N - Neutral
- L - Live for Electronics
- L1 - Phase 1 for Motors
- L2 - Phase 2 for Motors
- L3 - Phase 3 for Motors

Blind plug
For the use with Atex certified cable glands
(Size M25)

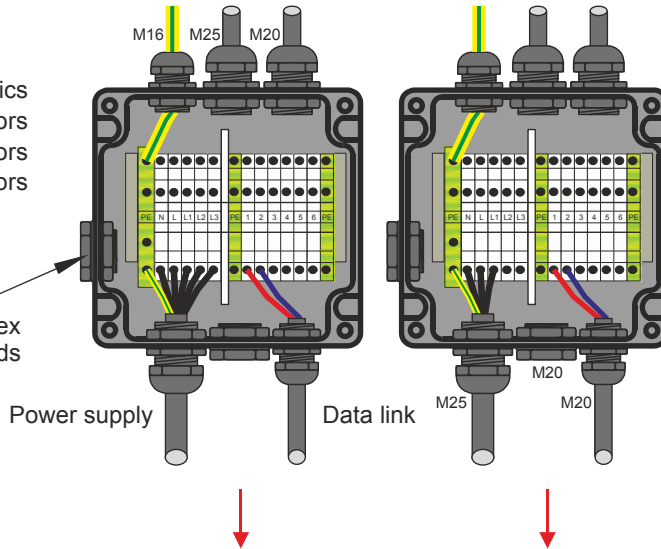

Single Phase Supply

230V +10% -15%, 50Hz ± 2Hz

Power supply

- PE - Main Earth
- N - Neutral
- L - Phase for Electronics
- L1 - Phase for Motors

The supply overcurrent protection devices should have a Break Capacity of not less than 4000A

Gas station

Three Phase Supply for STP and Crind

400V ± 10% , 50Hz ± 2Hz
230V +10% -15%, 50Hz ± 2Hz

Power supply

- PE- Main Earth
- N- Neutral Crind
- L- Live for Crind
- N- Neutral Heater
- L- Live für Heater
- N- Neutral Calculator
- L- Live for Calculator
- L1- Phase 1 VRC- Motor
- L2- Phase 2 VRC- Motor
- L3- Phase 3 VRC- Motor
- M1 - STP Grade 1
- M2 - STP Grade 2
- M3 - STP Grade 3
- M4 - STP Grade 4
- M5 - STP Grade 5
- M6 - STP Grade 6

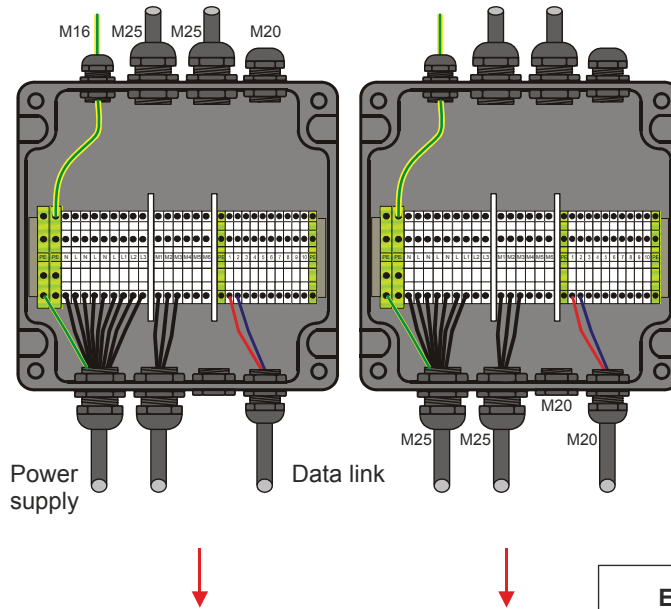

Single Phase Supply for STP and Crind

230V +10% -15%, 50Hz ± 2Hz

Power supply

- PE- Main Earth
- N- Neutral Crind
- L- Live for Crind
- N- Neutral Heater
- L- Live für Heater
- N- Neutral Calculator
- L- Live for Calculator
- L1- Phase 1 VRC- Motor
- M1 - STP Grade 1
- M2 - STP Grade 2
- M3 - STP Grade 3
- M4 - STP Grade 4
- M5 - STP Grade 5
- M6 - STP Grade 6

Electrical connection
Please note the local & national regulations regarding electrical installations. Electrical cables must be oil and fuel resistant.

Gas station

16 Proposal for suction dispenser & vapour connections

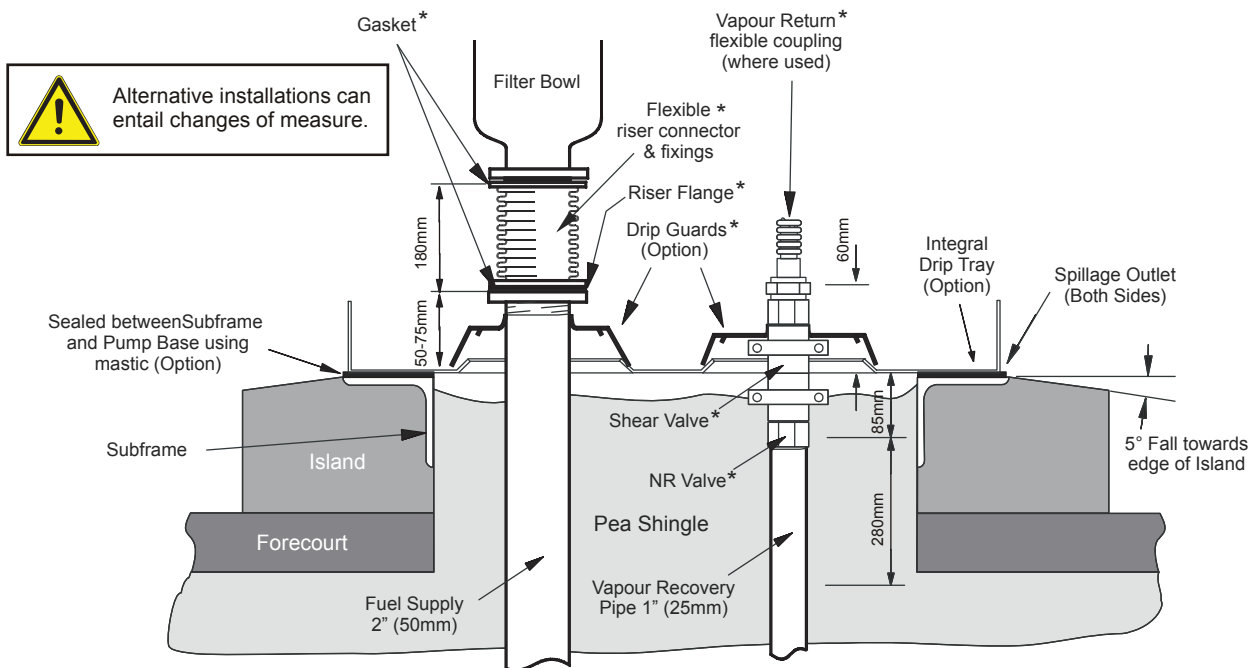

* Items supplied by Gilbarco (optional)

16.1 Subframes

Gilbarco recommend that dispensers be mounted on subframes that have been installed prior to the installation of the dispenser. In some cases a pre-fabricated island with integral subframe may be installed. Subframes are set into the island during the forecourt preparation work and must be sealed to the island surface using a fuel and water resistant compound. They should stand proud of the finished surface of the island (inc. tiles where used) up to a maximum of 2mm. The surface of the subframe should be flat and level, however the island surface should be designed with at least 5° fall toward its outer edge. This is to ensure that any internal leakages dispersed through the base of the dispensers are directed away from the dispenser base and onto the forecourt.

The dispenser subframes are designed for use with 2" (50mm) Product Riser pipes and 1" (25mm) Vapour Recovery return pipes.

Subframes are available from Gilbarco, please see pages 3-6 for Part No.

16.2 Drip Guards

Drip Guards are to be fitted as shown, so that in the event of a spillage or leak, the excess fuel will be directed away from the riser position and onto the integral Drip Tray, it will then flow towards the apertures in the base of the dispenser frame and onto the surface of the forecourt. This clearly indicates that a leak is present and that repair is necessary.

16.3 Vapour Recovery Pipes

Where used, Vapour Recovery pipes should be installed using a non return or check valve before the shear valve. The break point of the VR shear valve should be set level with the top face of the island. This means that the top of the VR riser pipe needs to be set 85mm below the top of the subframe. The riser pipe should terminate with a 1" BSPT male thread with a minimum of 20mm of thread engagement.

16.4 Proposal for suction dispenser fuel connections – plastic pipework

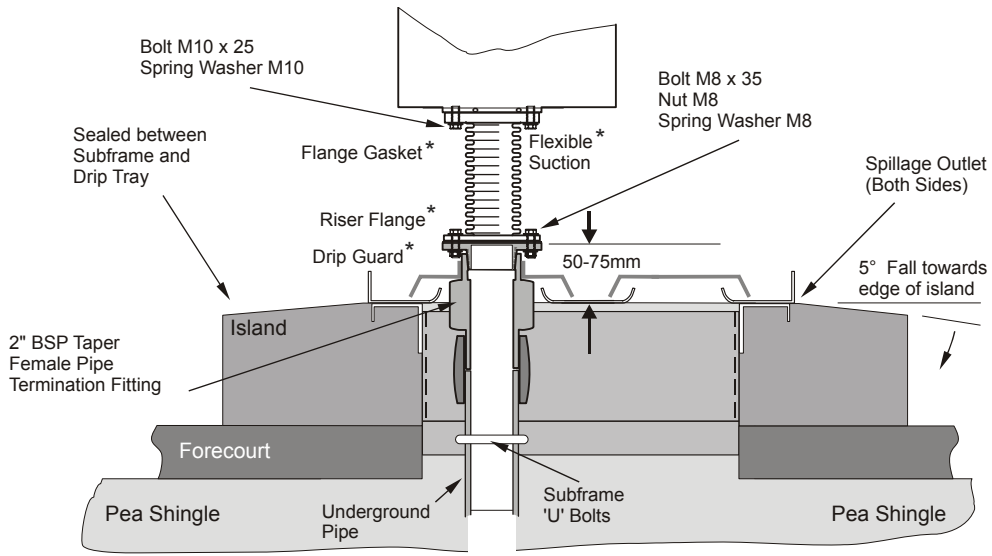

* Items supplied by Gilbarco (optional)

16.5 Dimensions for STP connections

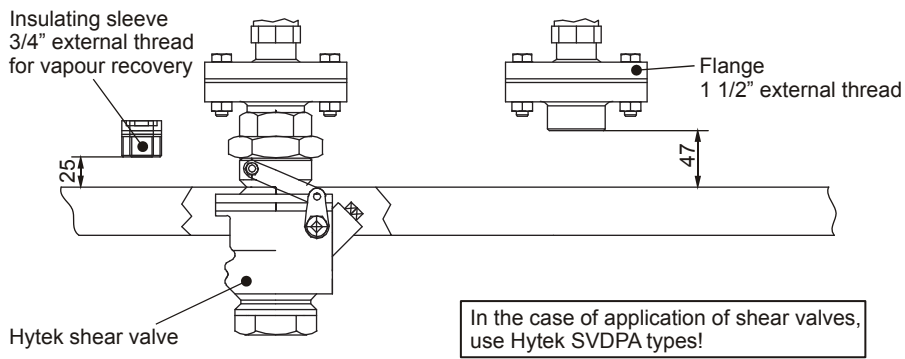

16.6 Proposal for shear valve connection with STP

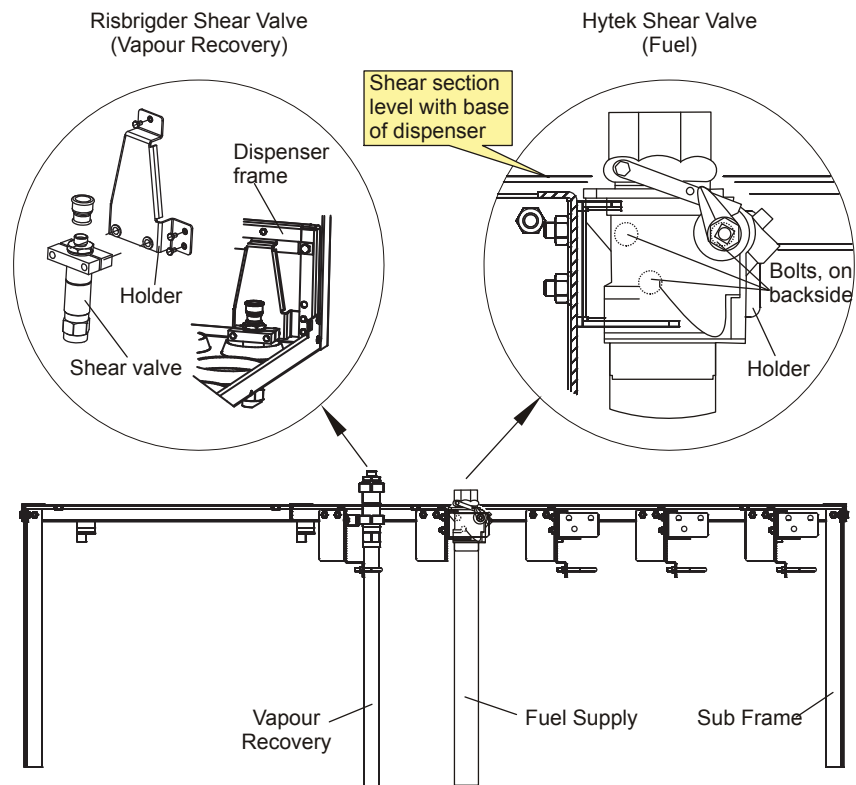

16.7 Operation conditions STP

The pumps must be implemented either as Submerged Turbine Pumps (STP), which are arranged within the respective storage tank in its deepest place, or as more deeply lying pumps with inlet. A checking device for the liquid level in the storage tanks is necessary, which gives a warning signal by a low level and switches the pumps off, before air or vapour can penetrate into the supply line. The piping must be installed underground. Directly behind the pump, a check valve needs to be installed in each line. If the lines are in its highest position no more than 1m above the man hole cover height, then a check valve is not required.

Inside the dispenser, a check valve is to be fitted in front of the volume meter. The installation of gas separators and gas indicators are not necessary.

Where a dispenser is supplied without an integrated drip pan, normally STP, other means to prevent leakage from entering the ground beneath the dispenser should be provided!



After Sales & Technical Support

Local Market
GVR Distributor

International Tel: +49 5258 130
Fax: +49 5258 13262